

PUMP CONDITION MONITOR



PRINCIPAL FEATURES

- **Outboard Seal status - barrier oil**
- **Inboard Seal/Terminal Box status - moisture**
- **Bearing Temperature indication**
- **Motor Winding status**
- **Motor Run/Stop - Starting Frequency**
- **Signal cable integrity**
- **Data retention**

BPL's Condition Monitor is designed to provide local operators with the status of various protection devices and performance indicators fitted into modern submersible pumps



SEALS

The primary seal status is monitored by the presence of moisture in the oil chamber and this is indicated on the display monitor. This feature offers a warning of impending seal failure enabling planned maintenance to be instigated. The seal status display is based on an arbitrary percentage, 100% being satisfactory, 0% alarm/trip condition.

Moisture in the motor housing is monitored indicating secondary seal status, the failure of which results in a trip.

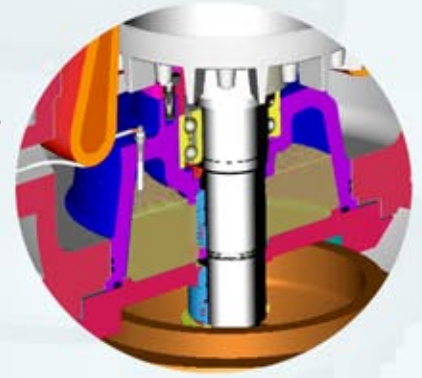

BEARINGS

When fitted, bearing temperature sensors enable actual bearing temperatures to be displayed on the monitor. Alarm and trip settings are adjustable.

MOTOR WINDING TEMPERATURE

Motor winding protection thermistors are monitored and trip conditions signalled and recorded. This device replaces the conventional thermistor relays.

CABLE FAULTS

Signal cable faults, short or open circuits are detected, indicated, alarmed and recorded.

TERMINAL BOX

Moisture detected in the motor terminal box will be detected, and a trip initiated and recorded.

DATA ACQUISITION

All significant changes of state are date-stamped and recorded for a rolling 3 month period, providing historical information for the machine. Alarms and trips can be configured to suit individual machines and stored data can be down-loaded via USB connection for record purposes (password protected).

A combination of text-display and LED slow and fast flashes provide local and remote indication.



REMOTE CONTROL

As an addition to the machine-supervisory features provided by the Pump Condition Monitor, a logger and auto-dialler can be attached to extend the recording and signalling capabilities. The logger can be remotely interrogated from your PC, and programmed to transmit data on a regular basis if required. Specific alarm conditions can be arranged to trigger SMS text message or email to a number of pre-determined recipients. These settings and options can be remotely reprogrammed. Machine protection is unaffected by these features. This system can be extended to provide monitoring of most common signals.

COMPLIANCE:

Each unit is supplied with an EC Declaration of Conformity and is CE marked on the basis that it will be installed in accordance with regulatory conditions.

The units are installed as part of a control circuit, assembled within a control panel which meets the requirements of BS EN60439-1:1999 Low Voltage Switchgear and Control Assemblies Part 1 specification, for type-tested and partially type-tested assemblies.



BEDFORD PUMPS LTD.
Part of the *Hydrotel* group of companies

Brooklands Woburn Road Industrial Estate, Kempston, Beds. MK42 7UH Tel: +44 (0)1234 852071
Fax: +44 (0)1234 856620 email: sales@bedfordpumps.co.uk Web: www.bedfordpumps.co.uk

