

# SUBMERSIBLE PUMPS

## SV RANGE

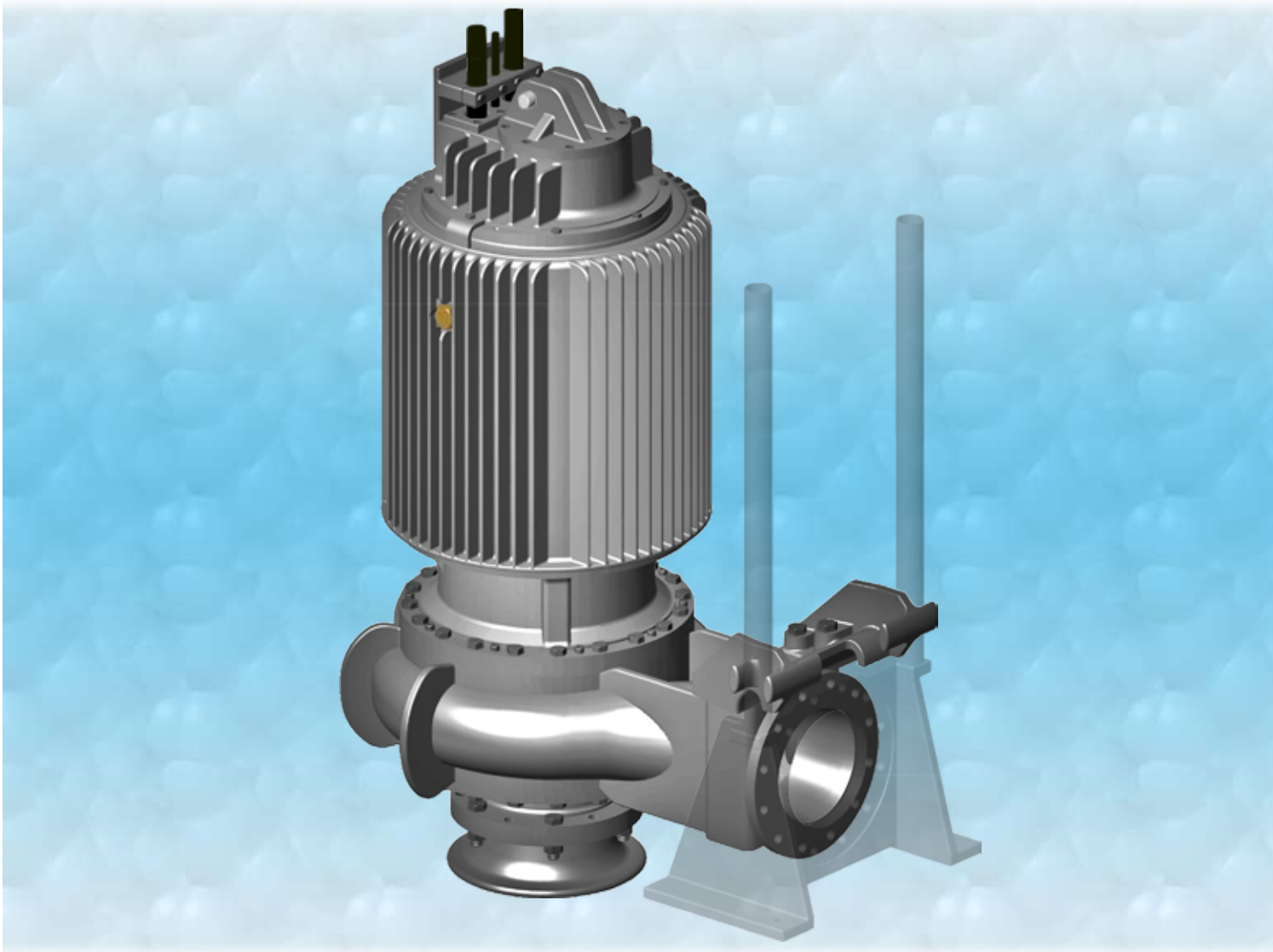

## TYPICAL APPLICATIONS

- **General Industrial Duties**
- **Power Stations**
- **Dock - Dewatering & Impounding**
- **Surface and Storm Water**
- **Sewerage Treatment & Disposal**
- **Waterworks**
- **Abrasive & Non-abrasive slurries**

BPL's versatile range of Submersible Volute Pumps is ideally suited to handling raw and foul water containing solids.

The design features an advanced motor oil cooling jacket to maintain cool motor operation when used in dry well or exposed wet well environments.



**Cable**  
Heavy duty, rubber sheathed cables to BS 7919.

**Bearings**  
Pre-lubricated angular contact thrust bearings & deep groove ball journal bearings. Designed for extended life.

**Instrumentation**  
Thermal overload thermistors, embedded in motor windings, and seal leakage sensors fitted as standard. Optional bearing temperature probes.

**Mechanical Seals**  
Two high quality, independently mounted, seals in an oil-filled enclosure to prevent water ingress to motor.

**Pump Casing**  
Cast Iron construction with easily renewable wear ring. A handhole is included as standard in dry-well versions.

**Terminal Box**  
High integrity IP68 design. Easy access to terminal plate without removing cables. Alternative cable entry positions to facilitate cable layout on site. Also available for EN50 019 (EExe) requirements.

**Motor**  
High efficiency squirrel cage induction design to BS 4999, Class F insulation. Suitable for : star delta, D.O.L., inverter or auto-transformer starting. Enclosures designed to EN50 018 (EExd) are available.

**Motor Cooling**  
For Dry-Well or exposed motors in Wet-Well installations, cooling is effected by heat transfer oil circulated around the motor casing by an auxiliary impeller, mounted between the mechanical seals. The oil is cooled by the pumped fluid in conjunction with a special cover/heat exchanger. This totally sealed system is separate from the pumped media and does not normally require any external cooling.

**Impeller**  
High efficiency, shrouded design of cast construction. Capable of handling solids & fibrous material. Statically & dynamically balanced prior to assembly.

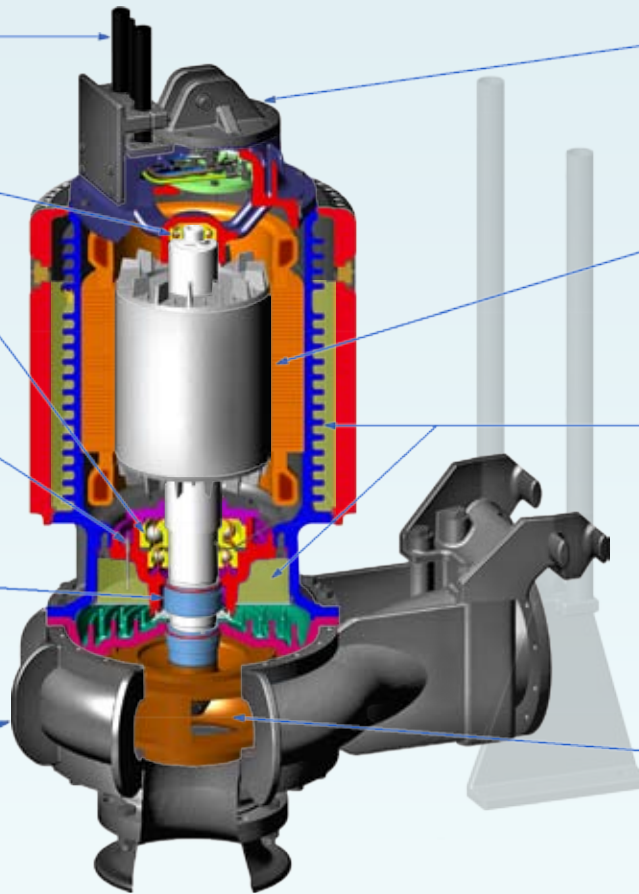

**Materials of Construction**

Motor casing	-	SG Cast Iron BS EN 1563 Gr.420/12
Pump Casing	-	SG Cast Iron BS EN 1563 Gr.420/12
Casing Wear Ring	-	SG Cast Iron BS EN 1563 Gr.420/12
Cast Components	-	Cast Iron BS EN 1561 Grade 250
Pump Shaft	-	Carbon Steel BS 970 070 M20
Impeller	-	SG Cast Iron BS 2789 Grade 420/12

Alternative material options and seal face combinations are available.

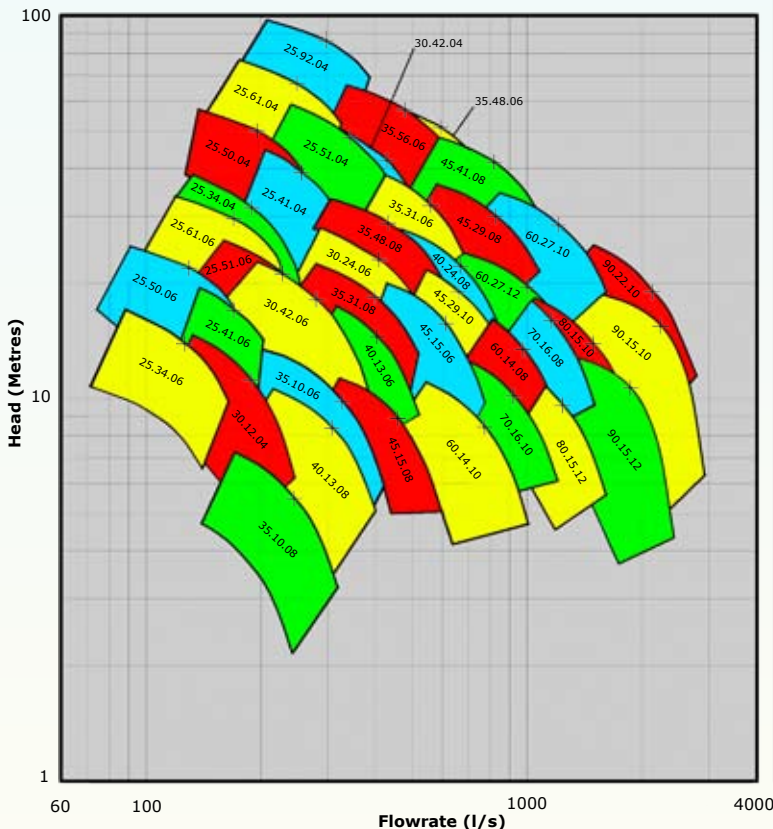

**Typical Arrangements**

This versatile pump can be installed either totally submerged in a wet well or in a dry chamber.

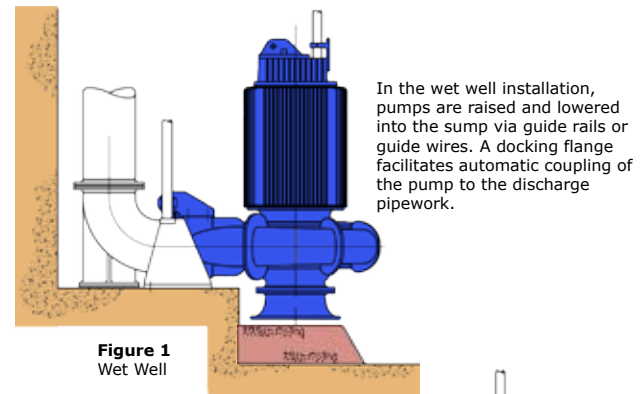

**Figure 1**  
Wet Well

In the wet well installation, pumps are raised and lowered into the sump via guide rails or guide wires. A docking flange facilitates automatic coupling of the pump to the discharge pipework.

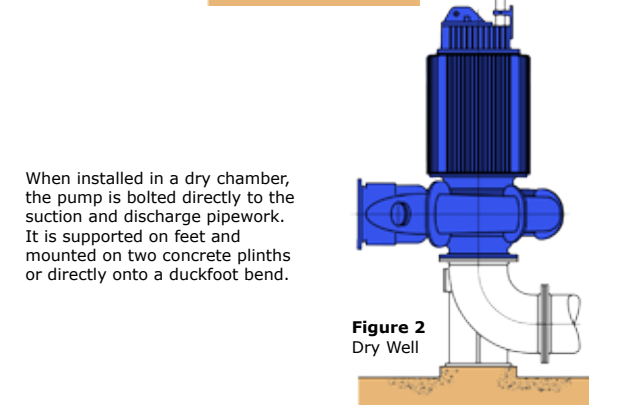

**Figure 2**  
Dry Well

When installed in a dry chamber, the pump is bolted directly to the suction and discharge pipework. It is supported on feet and mounted on two concrete plinths or directly onto a duckfoot bend.



**BEDFORD PUMPS LTD.**

Brooklands Woburn Road Industrial Estate, Kempston, Beds. MK42 7UH Tel: +44 (0)1234 852071  
Fax: +44 (0)1234 856620 email: sales@bedfordpumps.co.uk Web: www.bedfordpumps.co.uk

